

Technical specifications sheet

Part number **290152351040D**

Description **DPVF 15/4 B~Flanged NW50~4kW 400/690V~50Hz 2P~IEC 112M~~Fixed Ca Sic EPDM**

Vertical centrifugal pump, suction and discharge connections in-line.

Quotation details

Quotation number

Project

Position

Search criteria

Medium to be pumped	Water
Flow	8.00 l/sec
Pressure	45.0 mwc

Hydraulic efficiency

Minimum efficiency index according: MEI ? 0.40
Commission Regulation (EU) No 547/2012

Actual duty point

Flow	9.1 l/sec
Pressure	45.2 mwc
NPSH	1.4 m
Efficiency	65.5 %
Motor power	6.16 kW
Frequency	50.0Hz
No of duty pumps	2

Best efficiency point

Flow	9.6 l/sec
Pressure	43.8 mwc
NPSH	1.6 m
Efficiency	65.6 %
Motor power	6.28 kW
Frequency	50Hz

Connection base

Connection type	Flanged
DIN connection standard	EN 1092-2
ASME connection standard	
JIS connection standard	
DIN connection size	NW50
ASME connection size	
JIS connection size	
DIN connection pressure class	PN25/40
ASME connection pressure class	
JIS connection pressure class	
Material S/D casing	AISI304
Material flanges	Cast Iron JS1030
Material baseplate	Cast Iron JL1040

Seal data

Shaft diameter	ø 16mm
Seal diameter	ø 16mm
Construction shaft seal	Fixed
Seal code	11
Shaft seal type	MG12-G60
Material mechanical seal	B Q1 E GG
Material shaft seal rotor	Ca
Material shaft seal stator	Sic
Material shaft seal elastomer	EPDM
Material pump elastomer	EPDM
Material seal cover	
Pressure class shaft seal	PN10
Temperature range shaft seal	-20/+100 °C

Basic hydraulic data

Maximum working pressure	PN25+100 °C
Maximum liquid temperature	140 °C+PN16
Minimum liquid temperature	-20 °C
Material hydraulic	AISI304

Plug

Air relieve construction	Vent. plug
Material plug	AISI304

For details contact

DP Pumps
PO Box 28
2400AA Alphen a/d Rijn
The Netherlands

NL



Hydraulic performance sheet

Part number **290152351040D**

Description **DPVF 15/4 B~Flanged NW50~4kW 400/690V~50Hz 2P~IEC 112M~~Fixed Ca Sic EPDM**

Vertical centrifugal pump, suction and discharge connections in-line.

Search criteria

Medium to be pumped

Flow 8.00 l/sec
 Pressure 45.0 mwc

Actual duty point

Flow 9.10 l/sec
 Pressure 45.2 mwc
 Efficiency 65.5 %
 NPSH 1.4 m
 Power 6.16 kW
 Frequency 50.0Hz

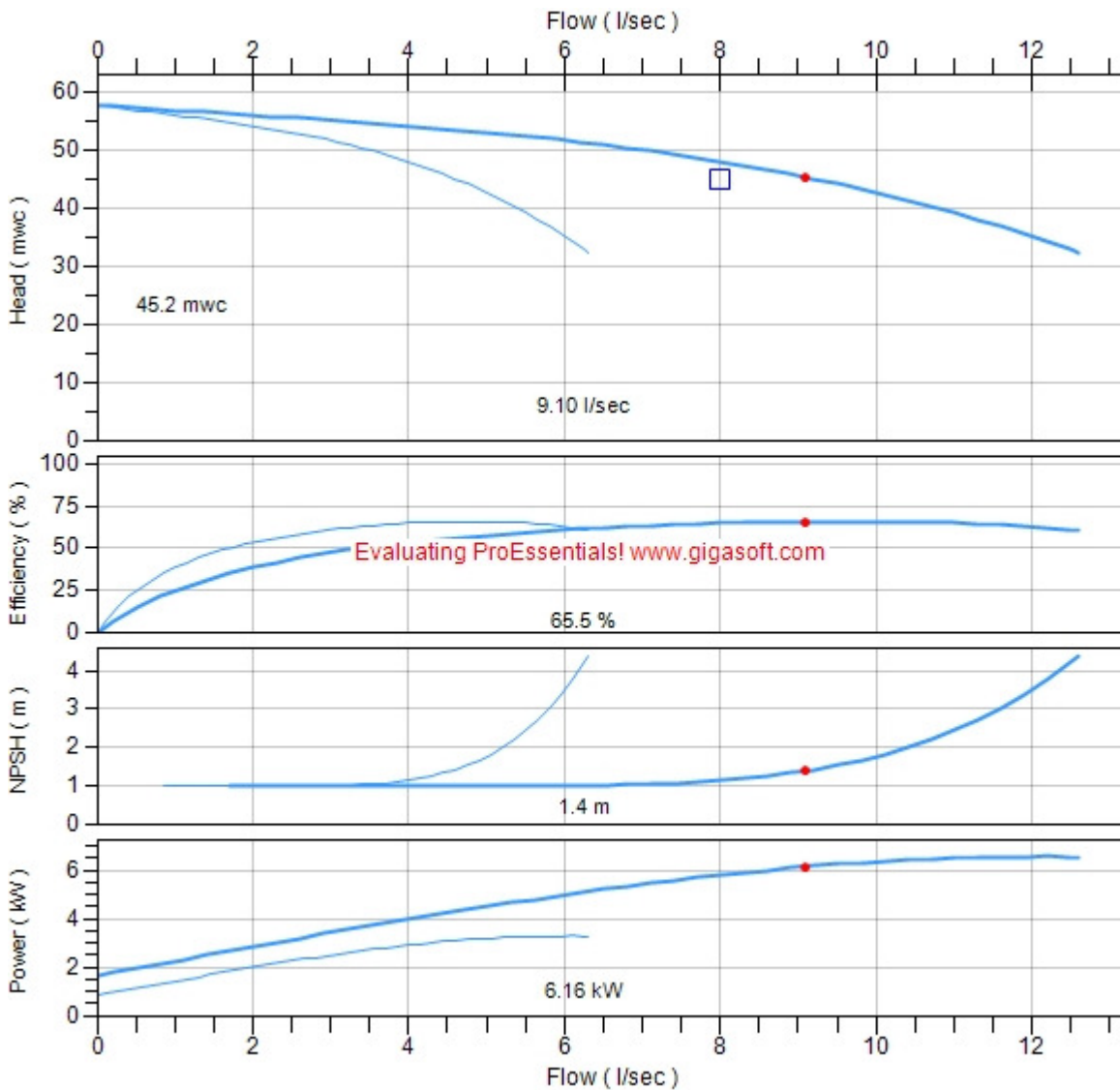

Duty Point
 ● Actual
 □ Required

Dimensions sheet

Part number **290152351040D**

Description **DPVF 15/4 B~Flanged NW50~4kW 400/690V~50Hz 2P~IEC 112M~~Fixed Ca Sic EPDM**

Vertical centrifugal pump, suction and discharge connections in-line.

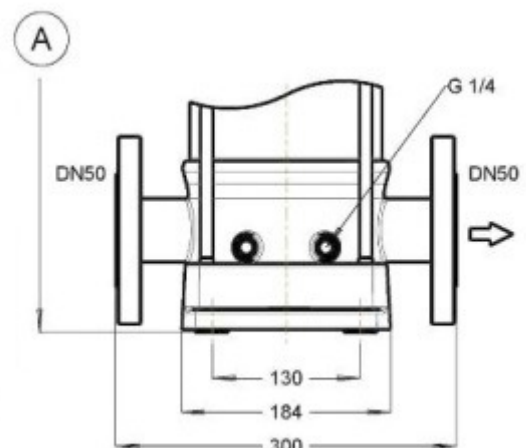
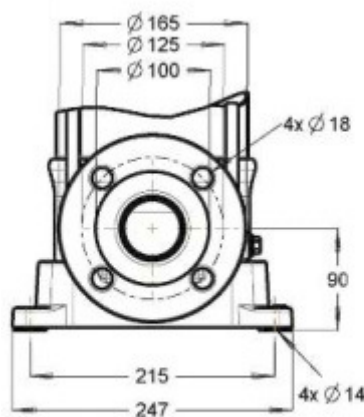
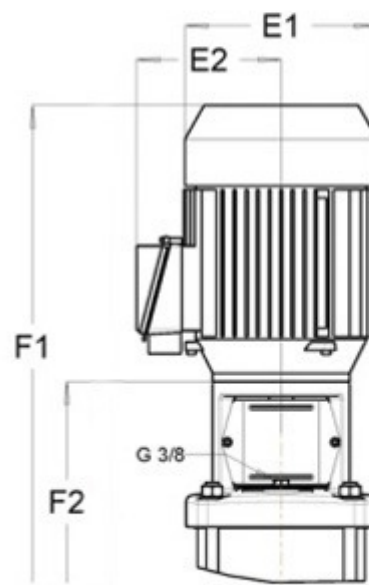

Motor width (E1)	233mm
Motor width (E2)	167mm
Total height (F1)	759mm
Total height (F2)	429mm
Total net weight	62kg

Motor specifications

Part number **3710112040**

Description **Motor DMC 4kW 400/690V 2P IE2 112M IP55 3xPTC Pos. 801**

Electric Data

Rated power output	4kW
Maximum power output	5,3kW
Rated voltage	400/690V
Phases	3ph
Frequency	50/60Hz
Voltage range	360-440/621-759V
Motor poles	2P
ATEX class	
Duty class	S1
Insulation class	F (rise-B)
Moment of inertia	0,006kgm ²
Motor standard	IEC
Capacitor	
Motor efficiency	86,3/87,5%
Motor efficiency class	IE2

50Hz

Tolerance rated voltage	±10%
Rated speed	2915rpm
Starting current factor (Ia/In)	8.5
Rated current (In)	7,7/4,5A
Maximum current (Imax)	8,8/5,1A
Rated Cos phi	0.87
Sound pressure	59dB(A)
Rated nominal torque	13,1Nm
Rated starting torque	31,4Nm

60Hz

Tolerance rated voltage	+20%,-10%
Rated speed	3495rpm
Starting current factor (Ia/In)	7.3
Rated current (In)	7,3/4,2A
Maximum current (Imax)	8,8/5,1A
Rated Cos phi	0.91
Sound pressure	62dB(A)
Rated nominal torque	10,9Nm
Rated starting torque	18,6Nm

Motor protection

Motor protection class	IP55
Temperature sensor	3xPTC
Rain cover	
Anti condensation heater	

Mechanical data

Shaft execution	smooth shaft
Maximum starts per hour	30
Cable gland	2xM20x1,5
VFD allowance	VFD allowed

Dimensions

Diameter shaft A1	28mm
Length shaft A2	60mm
Diameter motor E1	233mm
Terminal box height E2	167mm
Diameter flange P	160mm
L. motor (without shaft) LB	322mm
Frame size	112M
Motor construction type	IM V18
Motor face	IEC 60034-7 Form FT 130

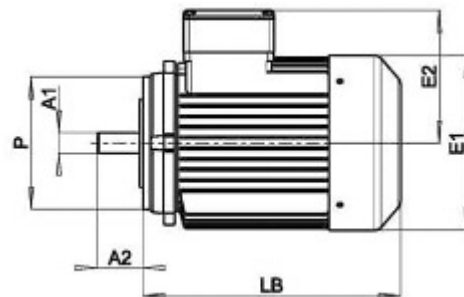

Bearings / lubrication

Grease nipple	
Bearing fixation pos	D-end
D-end bearing type	6306-2Z-C3
Bearing grease	Lithium based -20%/+160

Details

Motor label	DMC
Weight	32kg
Lifting lugs	1 x M10
Motor finish	RAL5002
Rated max. amb. temp.	40 °C
Material housing	Aluminium